

MIG/MAG Welding Torch MB 24 KD air-cooled



BINZEL. The right welding torch for every job!

BINZEL air cooled welding torches incorporate the high quality and technology needed for trouble-free performance whatever the welding job. All BINZEL torches are constructed to the highest standards and offer the greatest working comfort.

BINZEL torch features:

- Optimum cooling of the torch, extending torch life
- An ergonomic handle, ensuring comfort in every position
- Light and flexible cable assemblies, designed to reduce fatigue

Technical data (EN 50 078):

Rating: 250 A CO₂
220 A Mixed Gases M 21 (DIN EN 439)
35% Duty Cycle
Wire sizes: 0.8 - 1.2

- Robust construction for durability and extended torch life
- A connecting system that allows easy torch changeover

Rated using power source with VDE standard volt/amp characteristic (U=14+0,05xI).
When pulse welding, reduce rating by 35%.

Type	Handle/Version	3.00 m long	4.00 m long	5.00 m long
		Part no.	Part no.	Part no.
MB 24 KD	Ergonomic	012.0103	012.0104	012.0105
AUT 24 KD	Handle tube, straight	912.0009	Special lengths	
	Handle tube, bent	912.0012	upon request!	

Welding & cutting brought to the point.



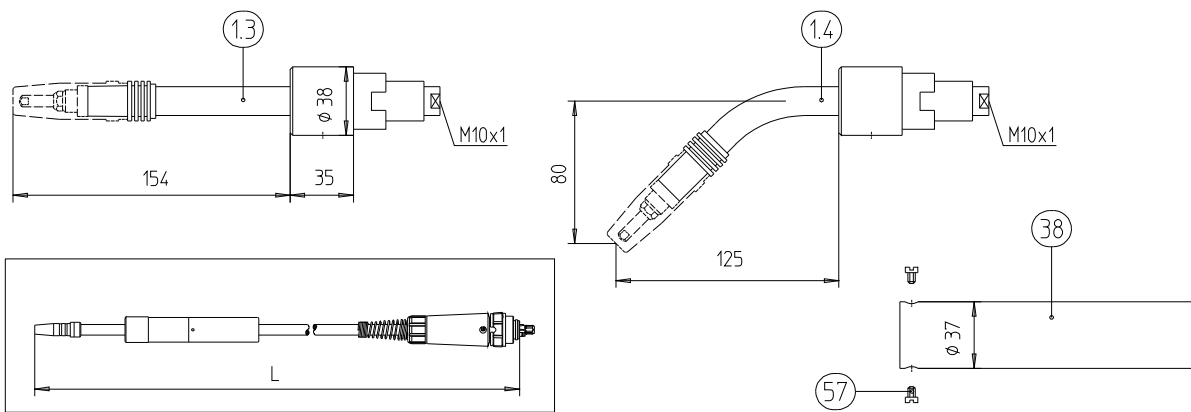
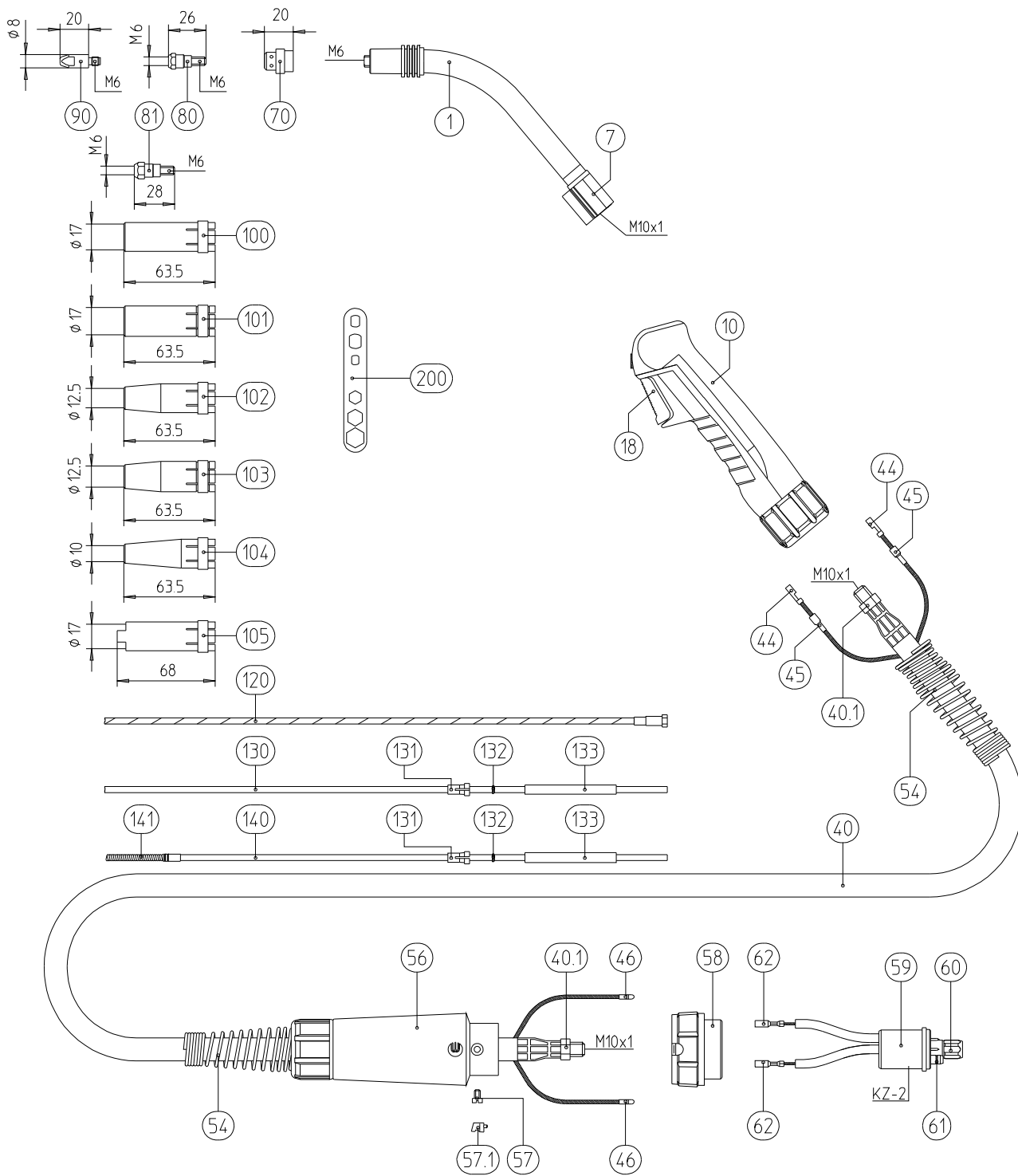

Build group	Pos.	Description	Specifications	Part no.	
Torch	1	Swan neck MB 24 KD, 50° bent		012.0001	
	1.3	Swan neck AUT 24 KD, straight		912.0001	
	1.4	Swan neck AUT 24 KD, 45° bent		912.0002	
	7	Torch body, plastic		400.0044	
Handle	10	Ergonomic handle, cpl., with trigger		180.0076	
		Handle, top		400.0333	
		Handle, bottom		400.0335	
		Lock ring NW 31		400.0297	
		Screw 18x8	20 pcs.	400.0340	
		Screw 3.5x9.5	20 pcs.	079.0034	
	18	Trigger 2 pol.		185.0031	
	38	Handle tube AUT		180.0001	
	Cable assembly	40	Bikox power cable 3.00 m	B6	160.0239
		Bikox power cable 4.00 m	B6	160.0255	
		Bikox power cable 5.00 m	B6	160.0267	
		w/o. fig. Outer cover for Bikox	per meter	by request	
40.1		Hexagon nut M10x1	10 pcs.	001.0009	
44		Trigger wire connector	20 pcs.	175.0022	
45		Insulating sleeve	20 pcs.	400.0119	
46		Trigger wire connector, male	20 pcs.	175.0004	
54		Cable support spring NW 19		500.0225	
56		Cable support machine side		501.2248	
57		Screw M4x6	20 pcs.	000.0552	
57.1		Covering cap 1	20 pcs.	500.0251	
58		Adaptor nut		500.0213	
59		Central adaptor block KZ-2 with control leads		501.0003	
		Central adaptor block KZ-2 without control leads		501.0028	
60		Nut M10x1	10 pcs.	501.0082	
61		O-ring 4x1	20 pcs.	165.0002	
62		Trigger wire connector, female	20 pcs.	175.0003	
Wear parts		70	Gas diffusor, white	• 10 pcs.	012.0183
		80	Contact tip holder M6, 26.0 mm	• 10 pcs.	142.0003
		81	Contact tip holder M6; 28.0 mm	10 pcs.	142.0010
		90	Contact tip M6 E-Cu, Ø 0.8 ³⁾	10 pcs.	140.0051
		Contact tip M6 E-Cu, Ø 1.0 ³⁾	• 10 pcs.	140.0242	
		Contact tip M6 E-Cu, Ø 1.2 ³⁾	10 pcs.	140.0379	
		Contact tip M6 CuCrZr, Ø 0.8 ³⁾	10 pcs.	140.0054	
		Contact tip M6 CuCrZr, Ø 1.0 ³⁾	10 pcs.	140.0245	
		Contact tip M6 CuCrZr, Ø 1.2 ³⁾	10 pcs.	140.0382	
		Contact tip M6 E-Cu, Ø 0.8 for alu wire ³⁾	10 pcs.	141.0001	
		Contact tip M6 E-Cu, Ø 1.0 for alu wire ³⁾	10 pcs.	141.0006	
		Contact tip M6 E-Cu, Ø 1.2 for alu wire ³⁾	10 pcs.	141.0010	
	100	Gas nozzle, cylindrical ND Ø 17.0	10 pcs.	145.0047	
	101	Gas nozzle, cylindrical, heavy duty ND Ø 17.0	10 pcs.	145.0062	

Build group	Pos.	Description	Specifications	Part no.
Wear parts	102	Gas nozzle, conical ND Ø 12.5	• 10 pcs.	145.0080
	103	Gas nozzle, conical, heavy duty ND Ø 12.5	10 pcs.	145.0101
	104	Gas nozzle, conical ND Ø 10.0	10 pcs.	145.0128
	105	Spot weld, gas nozzle ND Ø 17.0	10 pcs.	145.0174
	120	Guide spiral liner blank 1.5/4.5 blue with nipple for wire ¹⁾ Ø 0.6-0.8	for 3.00 m for 4.00 m for 5.00 m	124.0011 124.0012 124.0015
		Guide spiral liner blank 2.0/4.5 red with nipple for wire ¹⁾ Ø 1.0-1.2	• for 3.00 m • for 4.00 m • for 5.00 m	124.0026 124.0031 124.0035
	130	Teflon core liner 1.5/4.0 blue with collet and o-ring for wire ²⁾ Ø 0.6-0.8	for 3.00 m for 4.00 m for 5.00 m	126.0005 126.0008 126.0011
		Carbon Teflon core liner 2.0/4.0 red with collet and o-ring for wire ²⁾ Ø 1.0-1.2	for 3.00 m for 4.00 m for 5.00 m	126.0021 126.0026 126.0028
		Carbon Teflon core liner 1.5/4.0 with collet and o-ring for wire ²⁾ Ø 0.6-0.8	for 3.00 m for 4.00 m for 5.00 m	127.0002 127.0003 127.0004
		Carbon Teflon core liner 2.0/4.0 with collet and o-ring for wire ²⁾ Ø 1.0-1.2	for 3.00 m for 4.00 m for 5.00 m	127.0005 127.0007 127.0008
	131	Collet for core liner at Ø 4.0	20 pcs.	131.0001
	132	O-ring 3.5x1.5	20 pcs.	165.0008
	133	Guide tube for core liners up to Ø 4.0	200 mm	129.0461
	140	Combined wire guide cpl. polyamide/brass 2.0/4.0 for wire Ø 1.0-1.2	for 3.00 m for 4.00 m for 5.00 m	128.M002 128.M003 128.M004
	141	Brass spiral made up with sleeve	200 mm	001.0305
	200	Spanner	10 pcs.	191.0001

¹⁾ Applicable for GMA welding of un-alloyed and low alloyed steels (DIN 8555 and 8559).

²⁾ Applicable for GMA welding of aluminium (DIN 1732), copper and copper alloys (DIN 1733) and nickel/nickel alloys (DIN 1736); Also for use with GMA welding of stainless and heat resistant steels (DIN 8556).

³⁾ As an alternative: Packing unit 50 pcs. Specification of order: 140.xxxx.50 or 141.xxxx.50.
• Standard - Equipment

The positions indicating "per meter" are available in commercial lengths.

Welding & cutting brought to the point.



Alexander Binzel Schweißtechnik GmbH & Co. KG
P.O. Box 10 01 53 · D-35331 Giessen
Tel.: ++49 (0) 64 08 / 59-0
Fax: ++49 (0) 64 08 / 59-194
Internet: www.binzel-abicor.com

